

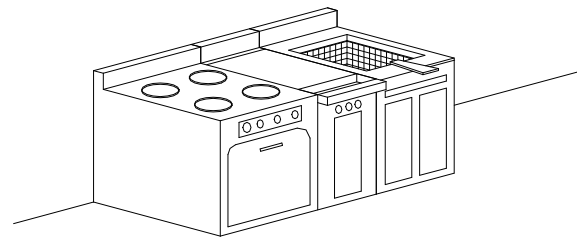

Dry Extractor

DD-B

Box Canopy
Dead Weight Fire Damper

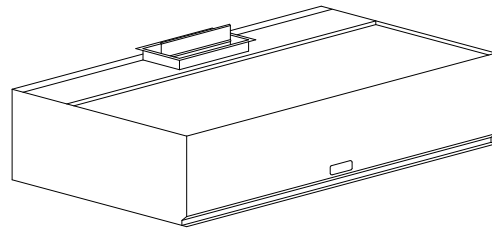

General Description

The dry ventilator is used on all cooking equipment. The unit is ceiling hung with a recommended mounting height of 6'-6" (1981 mm) from the lower edge of the canopy to the floor. The hood is finished with a number 4 finish on three sides. The box canopy can be tapered to fit into kitchens with ceilings as low as 7'-6" (2286 mm). The dry ventilator is available with fluorescent or incandescent lights wired to a J-box.

Efficiency

The hood is equipped with a high efficiency type "D" grease extractor. The high efficiency is achieved by applying maximum centrifugal force to the grease, dirt and lint particles through multiple, and abrupt, high velocity exhaust air direction changes.

The grease extractor design incorporates a vortex collection chamber, where the exhaust air accelerates 270 degrees around the vortex baffles and a secondary Variflow baffle for adjustable exhaust air flow. The vortex baffle is removable for periodic cleaning.

Exhaust and Supply

The total exhaust required to properly ventilate a commercial kitchen is directly related to the type of cooking equipment under the ventilator. An exhaust flow rate between 150 and 350 CFM/ft (233 and 544 l/s /m) is satisfactory for most applications. For detailed calculations refer to the *Spring Air Systems Ventilator Engineering Manual exhaust air section*. Introducing fresh air back into the kitchen is good engineering practice. An adequate supply of fresh air eliminates cold drafts, and hot spots, enhances the capture capability of the dry ventilator and results in a more comfortable kitchen environment. A supply volume between 80 and 90% is recommended. The fresh air should be heated to between 50 and 75F (13 and 24C).

Model DD-B

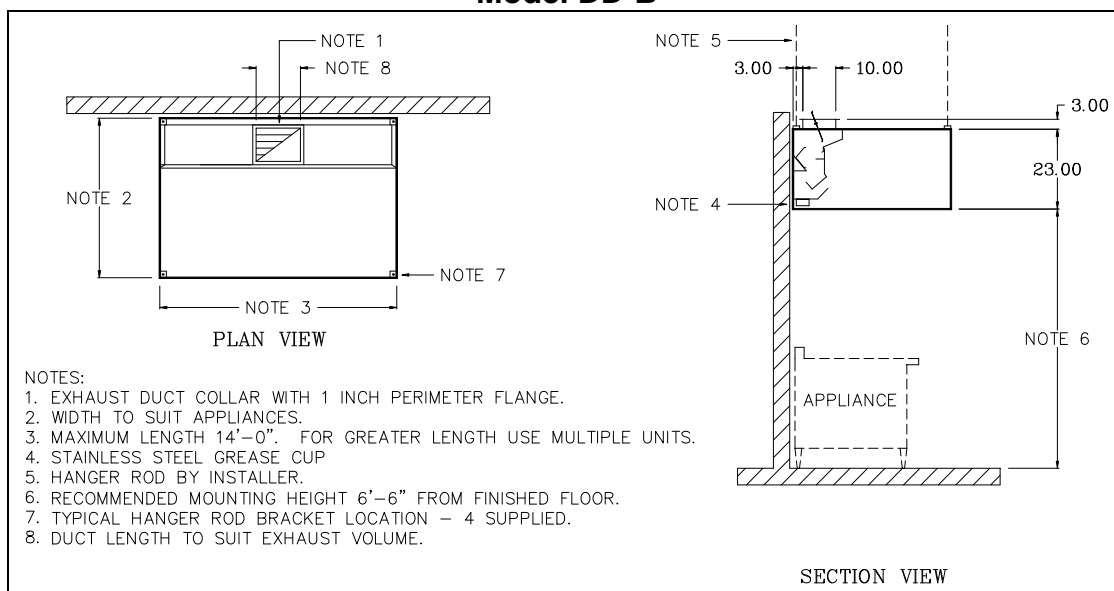

Engineering Data

Ventilator Length		Exhaust Flow Rate (EFR*)											
		Exhaust @ 250 CFM/ft (388 l/s/m)				Exhaust @ 300 CFM/ft (465 l/s/m)				Exhaust @ 350 CFM/ft (544 l/s/m)			
(ft)	(mm)	Exhaust volume (CFM)	Exhaust volume (l/s)	Exhaust Duct 10 in x	Exhaust Duct 254 in x	Exhaust volume (CFM)	Exhaust volume (l/s)	Exhaust Duct 10 in x	Exhaust Duct 254 in x	Exhaust Volume (CFM)	Exhaust Volume (l/s)	Exhaust Duct 10 in x	Exhaust Duct 254 in x
3.0	914	750	355	7	178	900	427	8	203	1050	498	9	229
3.5	1067	875	415	8	203	1050	498	9	229	1225	581	10	254
4.0	1219	1000	474	9	229	1200	569	11	279	1400	664	12.5	318
4.5	1372	1125	533	10	254	1350	640	12.5	318	1575	746	13.5	343
5.0	1524	1250	592	11	279	1500	711	13.5	343	1750	829	16	406
5.5	1676	1375	652	12.5	318	1650	782	14.5	368	1925	912	17	432
6.0	1829	1500	711	13.5	343	1800	853	16	406	2100	995	18	457
6.5	1981	1625	770	14.5	368	1950	924	18	457	2275	1078	20	508
7.0	2134	1750	829	16	406	2100	995	19	483	2450	1161	21.5	546
7.5	2286	1875	889	17	432	2250	1066	20	508	2625	1244	23.5	597
8.0	2438	2000	948	18	457	2400	1137	21.5	546	2800	1327	25	635
8.5	2591	2125	1007	19	483	2550	1209	22.5	572	2975	1410	26	660
9.0	2743	2250	1066	20	508	2700	1280	25	635	3150	1493	28	711
9.5	2896	2375	1126	21.5	546	2850	1351	26	660	3325	1576	30.5	775
10.0	3048	2500	1185	22.5	572	3000	1422	27	686	3500	1659	31.5	800
10.5	3200	2625	1244	23.5	597	3150	1493	28	711	3675	1742	32.5	826
11.0	3353	2750	1303	25	635	3300	1564	29	737	3850	1825	34	864
11.5	3505	2875	1363	26	660	3450	1635	31.5	800	4025	1908	36	914
12.0	3658	3000	1422	27	686	3600	1706	32.5	826	4200	1991	37	940
12.5	3810	3125	1481	28	711	3750	1777	34	864	4375	2073	39	991
13.0	3962	3250	1540	29	737	3900	1848	35	889	4550	2156	40.5	1029
13.5	4115	3375	1600	30.5	775	4050	1919	36	914	4725	2239	29.5	749
14.0	4267	3500	1659	31.5	800	4200	1991	38	965	4900	2322	31.5	800
14.5	4420	3625	1718	32.5	826	4350	2062	39	991	5075	2405	32	813
15.0	4572	3750	1777	34	864	4500	2133	40.5	1029	5250	2488	33.5	851

* Refer to the Ventilator Engineering Manual for Exhaust Volumes and Flow Rates not shown above.

Exhaust Flow Rate		Static Pressure at Duct Collar	
CFM/ft	l/s/m	in W.C.	kpa
150	233	0.62	0.155
250	388	1.00	0.250
300	465	1.26	0.315
350	544	1.15	0.288
400	620	1.38	0.345

Notes:

- Exhaust duct can be located anywhere along length of ventilator, discharge out the top, back or front.

bushing and edge seals shall be fully accessible through front removable grease inserts within the hood canopy. The grease trough shall be constructed of stainless steel with a stainless steel grease cup. The exhaust fire damper shall be an arrangement "D", butterfly type, constructed of stainless steel with blade and edge seals. The fire damper shall be activated by a fusible link and dead weight arrangement. The hood shall have _____ incandescent/fluorescent lights evenly spaced along the length of the hood.

Spring Air Systems Model No. DD-B Hood Specification

The dry extractor shall be a Spring Air Systems model no. DD-B, box canopy, high efficiency, dry ventilator, UL/ULC listed, and built in accordance with NFPA-96. The unit casing shall be a minimum 18 GA. stainless steel on all exposed surfaces.

The ventilator shall have a full length high velocity slot, a centrifugal vortex chamber, and a Variflow baffle. The vortex chamber shall provide a full 270 degree turn. The chambers, Variflow baffle, and the fire damper blades,

Engineering Data

Item Number: _____
 Model Number: _____
 Number of Sections: _____
 Hood Length: _____
 Hood Width: _____
 Exhaust Volume: _____
 No. of Duct Collars: _____
 Size of Duct Collar: _____
 Static Pressure: _____



Catalog Table of Contents



Dry Ventilator Table of Contents