

Island Dry Extractor



DN-DB

Double Box Canopy

General Description

The Ventilator is used on all cooking equipment in a double row island arrangement. The unit is ceiling hung with a recommended mounting height of 6' 6" (1981 mm) from the lower edge of canopy to the floor. The hood has a single grease extractor with double slot and adjustable VARIFLOW baffle and is especially designed for applications with heavy side, such as fryers, hot tops, and broilers, and a light side, such as ovens, kettles, and ranges. The unit is finished on all four sides with No. 4 finish. The double box canopy can be tapered into kitchens with ceilings as low as 7' 6" (2286 mm). The ventilator is available with fluorescent or incandescent lights.

Efficiency

The hood is equipped with a high efficiency type "D" grease extractor. The high efficiency is achieved by applying maximum centrifugal force to the grease, dirt and lint particles through multiple, abrupt, high velocity exhaust air direction changes.

The grease extractor design incorporates a VORTEX collection chamber, where the exhaust air accelerates 270 degrees around the VORTEX BAFFLES and a secondary VARIFLOW BAFFLE for adjustable exhaust air flow.

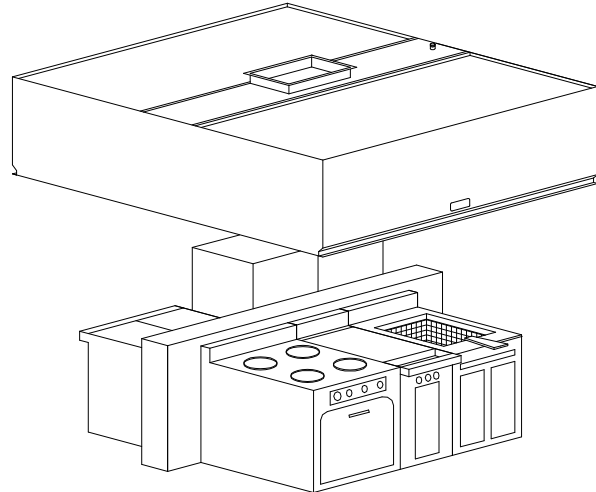

The VORTEX BAFFLE is removable for periodic cleaning.

Exhaust and Supply

The total exhaust required to properly ventilate a commercial kitchen is directly related to the type of cooking equipment under the ventilator. An exhaust flow rate between 300 and 700 CFM/ft (465 and 1085 l/s/m) is satisfactory for most applications. For detailed calculations refer to the *Spring Air Systems Ventilator Engineering Manual*.

Model DN-DB

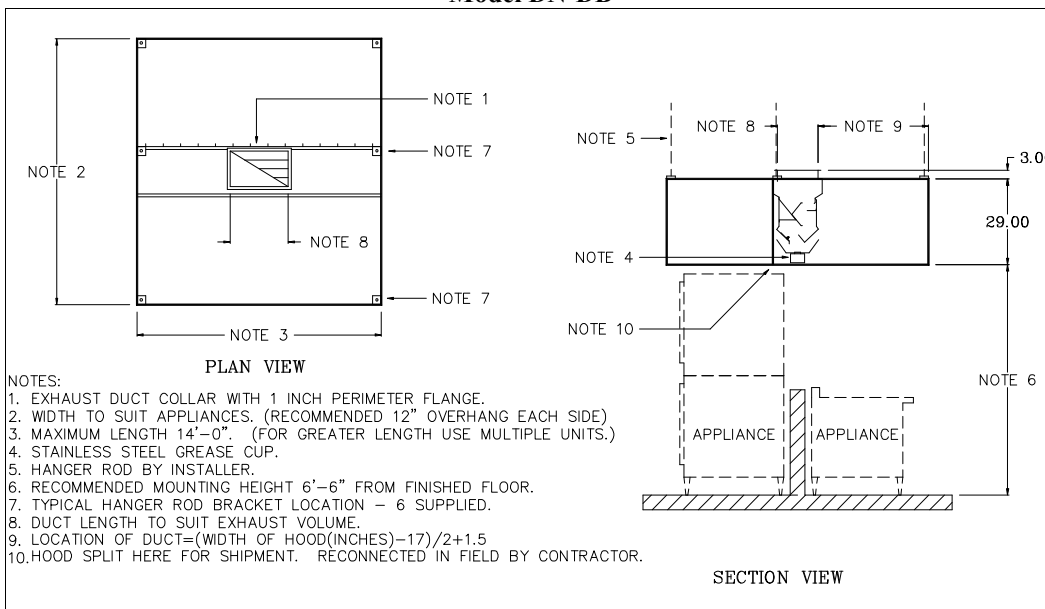

Engineering Data

Ventilator Length		Exhaust Flow Rate (EFR*)							
		Exhaust @ 400 CFM/ft (620 l/s/m)				Exhaust @ 500 CFM/ft (776 l/s/m)			
(ft)	(mm)	Exhaust volume (CFM)	Exhaust volume (l/s)	Exhaust Duct 10 in x	Exhaust Duct 254 in x	Exhaust volume (CFM)	Exhaust volume (l/s)	Exhaust Duct 10 in x	Exhaust Duct 254 in x
3.0	914	1200	569	10	254	1500	711	13.5	343
3.5	1067	1400	664	12.5	318	1750	829	16	406
4.0	1219	1600	758	13.5	343	2000	948	18	457
4.5	1372	1800	853	16	407	2250	1066	20	508
5.0	1524	2000	948	18	457	2500	1185	22.5	572
5.5	1676	2200	1043	19	483	2750	1303	25	635
6.0	1829	2400	1137	21.5	546	3000	1422	27	686
6.5	1981	2600	1232	22.5	572	3250	1540	29	737
7.0	2134	2800	1327	25	635	3500	1659	31.5	800
7.5	2286	3000	1422	27	686	3750	1777	34	864
8.0	2438	3200	1517	28	711	4000	1896	36	914
8.5	2591	3400	1611	30.5	775	4250	2014	38	965
9.0	2743	3600	1706	31.5	800	4500	2133	40.5	1029
9.5	2896	3800	1801	34	864	4750	2251	14 x 30.5	356 x 775
10.0	3048	4000	1896	36	914	5000	2370	14 x 32	356 x 813
10.5	3200	4200	1991	37	940	5250	2488	14 x 33.5	356 x 851
11.0	3353	4400	2085	39	991	5500	2607	14 x 35.5	356 x 902
11.5	3505	4600	2180	40.5	1029	5750	2725	14 x 37	356 x 940
12.0	3658	4800	2275	14 x 30.5	356 x 775	6000	2844	14 x 38.5	356 x 978
12.5	3810	5000	2370	14 x 32	356 x 813	6250	2962	14 x 40	356 x 1016
13.0	3962	5200	2464	14 x 33	356 x 838	6500	3081	16 x 36.5	406 x 927
13.5	4115	5400	2559	14 x 34.5	356 x 876	6750	3199	16 x 38	406 x 965
14.0	4267	5600	2654	14 x 35.5	356 x 902	7000	3318	16 x 39.5	406 x 1003
14.5	4420	5800	2749	14 x 37	356 x 940	7250	3436	16 x 41	406 x 1041
15.0	4572	6000	2844	14 x 38.5	356 x 978	7500	3555	16 x 42	406 x 1067

* Refer to the Ventilator Engineering Manual for Exhaust Volumes and Flow Rates not shown above.

Exhaust Flow Rate		Static Pressure at Duct Collar	
CFM/ft	l/s/m	in W.C.	kpa
300	465	0.8	0.20
350	544	0.93	0.23
400	62	1.05	0.26
500	776	0.93	0.23
600	930	1.11	0.28
700	1085	1.25	0.33

Notes:

- Exhaust duct can be located anywhere along length of ventilator, discharge out of the top, back or front.

Spring Air Systems Model No. DN-DB Hood Specification

The dry hood shall be a Spring Air Systems model no. DN-DB, double box canopy, island arrangement, high efficiency, dry extractor, UL/ULC listed, and built in accordance with the NFPA-96.

The double island canopy shall be constructed of a minimum 18 GA. stainless steel on all exposed surfaces. The hood shall be shipped in a minimum of two pieces, each piece UL/ULC listed, to be re-

connected on site with stainless steel bolts, retainers and caps.

The ventilator shall have two full length, high velocity slots, and a vortex and secondary extraction chamber and a VARIFLOW BAFFLE. The vortex chamber shall provide a full 270 degree turn. Both chambers and the VARIFLOW BAFFLE shall be fully accessible through removable doors within the hood OF the canopy.

The hood shall have incandescent/fluorescent lights evenly spaced along the length of the hood.

Engineering Data

Item Number: _____
 Model Number: _____
 Number of Sections: _____
 Hood Length: _____
 Hood Width: _____
 Exhaust Volume: _____
 No. of Duct Collars: _____
 Size of Duct Collar: _____
 Static Pressure: _____