

Filter Hood With Exhaust Fire Damper

FD-B-I

Single Row Box Canopy Island Arrangement

General Description

The filter hood is used on all cooking equipment. The hood is ceiling hung with a recommended mounting height of 6'6" (1981 mm) from the finished floor. The hood is finished in a No. 4 stainless steel finish on all four sides. The filter hood is available with fluorescent or incandescent lights.

Efficiency

The hood is equipped with high efficiency UL/ULC listed baffle grease filters. The exhaust air accelerates through multiple turns within the baffle filter. Centrifugal forces causes grease dirt and lint to deposit on the baffles. The liquefied grease drains down the baffles, along the grease trough, and into a grease cup.

Exhaust and Supply

The total exhaust required to properly ventilate a commercial kitchen is directly related to the type of cooking equipment under the filter hood. An exhaust flow rate between 250 and 400 CFM/ft is satisfactory

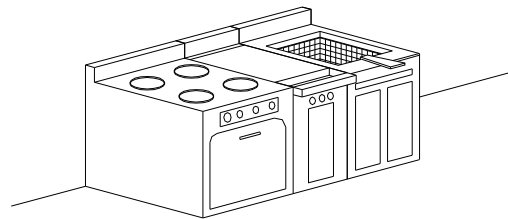
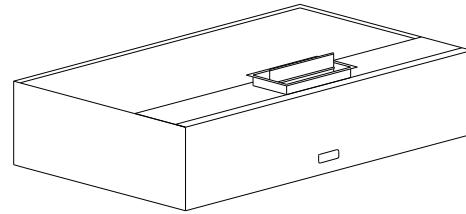

for most applications. Introducing supply air back into the kitchen is good engineering practice. An adequate supply of fresh air eliminates cold drafts, and hot spots, enhances the capture capability of the filter hood and results in a more comfortable kitchen environment. A supply air volume up to 80% of the total exhaust is recommended. The fresh air should be tempered to between 55 and 75F (13 to 24C)

Model FD-B-I

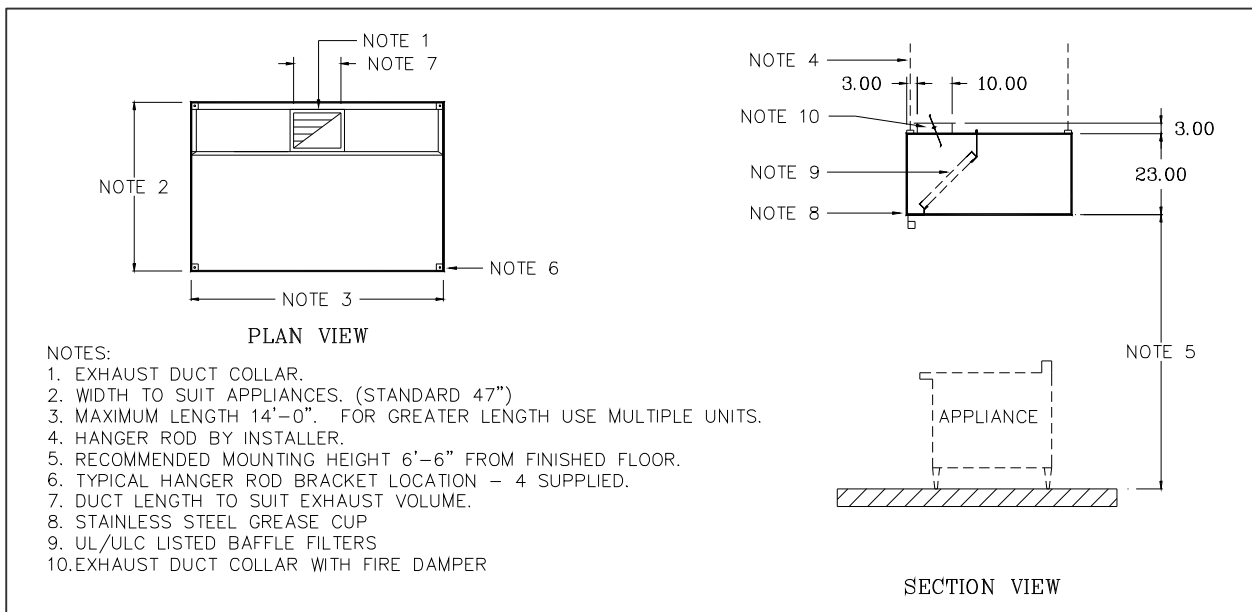

Engineering Data

Ventilator Length		Exhaust Flow Rate (EFR*)							
		Exhaust @ 350 CFM/ft (544 l/s/m)				Exhaust @ 400 CFM/ft (620 l/s/m)			
(ft)	(mm)	Exhaust Volume (CFM)	Exhaust Volume (l/s)	Exhaust Duct 10 in x	Exhaust Duct 254in x	Exhaust volume (CFM)	Exhaust volume (l/s)	Exhaust Duct 10 in x	Exhaust Duct 254in x
3.0	914	1050	498	9	229	1200	569	10	254
3.5	1067	1225	581	10	254	1400	664	12.5	318
4.0	1219	1400	664	12.5	318	1600	758	13.5	343
4.5	1372	1575	746	13.5	343	1800	853	16	407
5.0	1524	1750	829	16	406	2000	948	18	457
5.5	1676	1925	912	17	432	2200	1043	19	483
6.0	1829	2100	995	18	457	2400	1137	21.5	546
6.5	1981	2275	1078	20	508	2600	1232	22.5	572
7.0	2134	2450	1161	21.5	546	2800	1327	25	635
7.5	2286	2625	1244	23.5	597	3000	1422	27	686
8.0	2438	2800	1327	25	635	3200	1517	28	711
8.5	2591	2975	1410	26	660	3400	1611	30.5	775
9.0	2743	3150	1493	28	711	3600	1706	31.5	800
9.5	2896	3325	1576	30.5	775	3800	1801	34	864
10.0	3048	3500	1659	31.5	800	4000	1896	36	914
10.5	3200	3675	1742	32.5	826	4200	1991	37	940
11.0	3353	3850	1825	34	864	4400	2085	39	991
11.5	3505	4025	1908	36	914	4600	2180	40.5	1029
12.0	3658	4200	1991	37	940	4800	2275	14 x 30.5	356 x 775
12.5	3810	4375	2073	39	991	5000	2370	14 x 32	356 x 813
13.0	3962	4550	2156	40.5	1029	5200	2464	14 x 33	356 x 838
13.5	4115	4725	2239	29.5	749	5400	2559	14 x 34.5	356 x 876
14.0	4267	4900	2322	31.5	800	5600	2654	14 x 35.5	356 x 902
14.5	4420	5075	2405	32	813	5800	2749	14 x 37	356 x 940
15.0	4572	5250	2488	33.5	851	6000	2844	14 x 38.5	356 x 978

* Refer to the Ventilator Engineering Manual for Exhaust Volumes and Flow rates not shown above.

Exhaust Flow Rate		Static Pressure at Duct Collar	
CFM/ft	l/s/m	in W.C.	kPa
250	388	0.35	0.09
300	465	0.45	0.11
350	544	0.55	0.14
400	620	0.64	0.16

Notes:

- Exhaust duct can be located anywhere along length of the filter hood.
- For lengths greater than 14' (4270 mm) join multiple sections together

Spring Air Systems FD-B-I Hood Specification

The filter hood shall be a Spring Air Systems model no. FD-B-I, box canopy, high efficiency, filter hood, single row island arrangement, UL/ULC listed, and built in accordance with the NFPA-96. The unit casing shall be a minimum 18 GA, stainless steel and finished on four sides. The filter hood shall include UL/ULC listed baffle grease filters mounted in an integral stainless steel rack inclined at 45 degrees.

The filter rack shall include a full length stainless steel grease gutter and grease cup. The fire damper shall be an arrangement "D" butterfly type, constructed of 16 Ga. Steel with metal blade and edge seals. The fire damper is activated by a fusible link and dead weight arrangement. The hood shall have _____ fluorescent or incandescent lights evenly spaced along the length of the hood.

Engineering Data:

Item Number: _____
 Model Number: _____ FD-B-I _____
 Number of Sections: _____
 Hood Length: _____
 Hood Width: _____
 Lights: _____
Exhaust Specifications
 Exhaust Volume: _____
 No. of Duct Collars: _____
 Size of Duct Collar: _____
 Static Pressure: _____

FD-B-I