

Heated make-up Air Filter Hood

FD-B with MC

Box Canopy Hood Exhaust Fire Damper

General Description

The filter hood is used on all cooking equipment. The hood is ceiling hung with a recommended mounting height of 6'6" (1981 mm) from the finished floor. The hood is finished in a No. 4 stainless steel finish on all exposed sides. The box canopy can be tapered to 10" (254 mm) at the front. The filter hood is available with fluorescent or incandescent lights. The MC plenum is shipped loose. The tempered makeup air is discharged down, through a perforated stainless steel panel located on the front of the filter hood.

Efficiency

The hood is equipped with high efficiency UL/ULC listed baffle grease filters. The exhaust air accelerates through multiple turns within the baffle filter. Centrifugal force causes grease dirt and lint to deposit on the baffles. The liquefied grease drains down the baffles, along the grease trough, and into a grease cup.

Exhaust and Supply

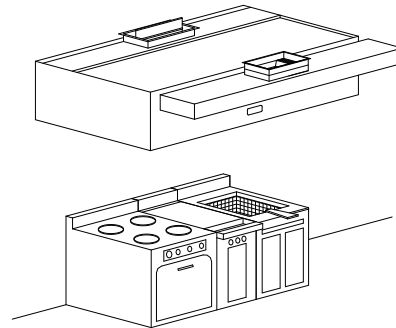

The total exhaust to properly ventilate commercial kitchen is directly related to the type of cooking equipment under the filter hood. An exhaust flow rate of between 150 to 400 CFM/ft (233 to 620 l/s/m) is satisfactory for most installations. Directing the make up air down, from the front of the hood provides continuous air movement, directed towards the cook.

Model FD-B with MC

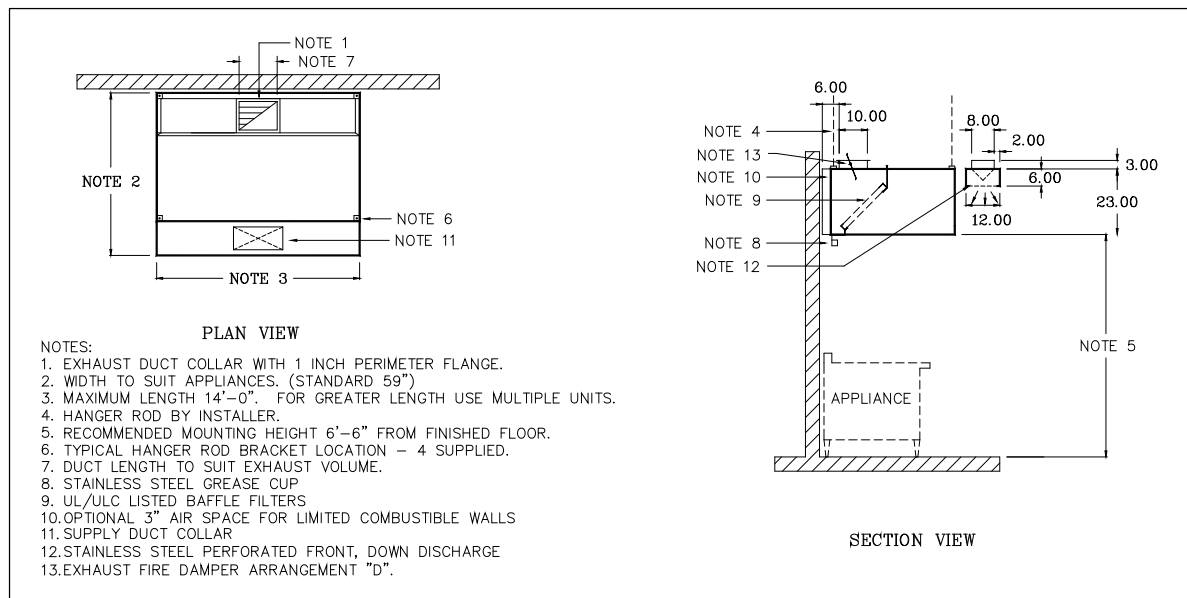

Engineering Data

VENTILATOR LENGTH		Exhaust Flow Rate (EFR) 300 CFM/ft. (465 l/s/m)					Exhaust Flow Rate (EFR) 350 CFM/ft. (544 l/s/m)				
		Exhaust		Supply Based on 80% of Exhaust			Exhaust		Supply Based on 80% of Exhaust		
		Volume	Duct Size	Volume	No. Ducts	Duct Size	Volume	Duct Size	Volume	No. Ducts	Duct Size
ft.	mm	CFM	L (in.) W=10	CFM		L (in.) W=8	CFM	LxW (in.)	CFM		L (in.) W=8
3.0	914	900	8	720	1	12	1050	10x9	840	1	14.5
3.5	1067	1050	9	840	1	14.5	1225	10x11	980	1	17
4.0	1219	1200	11	960	1	16	1400	10x12.5	1120	1	18.5
4.5	1372	1350	12.5	1080	1	18.5	1575	10x14.5	1260	1	21
5.0	1524	1500	13.5	1200	1	20.5	1750	10x16	1400	1	24
5.5	1676	1650	14.5	1320	1	22	1925	10x17	1540	1	26.5
6.0	1829	1800	16	1440	1	24.5	2100	10x19	1680	1	29
6.5	1981	1950	18	1560	1	26.5	2275	10x20	1820	1	30.5
7.0	2131	2100	19	1680	1	29	2450	10x22.5	1960	1	33
7.5	2286	2250	20	1800	1	30.5	2625	10x23.5	2100	1	35.5
8.0	2438	2400	21.5	1920	1	32	2800	10x25	2240	2	18.5
8.5	2591	2550	22.5	2040	1	35	2975	10x27	2380	2	20.5
9.0	2743	2700	25	2160	1	36.5	3150	10x28	2520	2	21
9.5	2896	2850	26	2280	2	19.5	3325	10x29	2660	2	23
10.0	3048	3000	27	2400	2	20.5	3500	10x31.5	2800	2	24
10.5	3200	3150	28	2520	2	21	3675	10x32.5	2940	2	24.5
11.0	3353	3300	29	2640	2	22	3850	10x35	3080	2	26.5
11.5	3505	3450	31.5	2760	2	24	4025	10x36	3220	2	27
12.0	3658	3600	32.5	2880	2	24.5	4200	10x38	3360	2	29
12.5	3810	3750	34	3000	2	25.5	4375	10x39	3500	2	29.5
13.0	3962	3900	35	3120	2	26.5	4550	10x40.5	3640	2	30.5
13.5	4115	4050	36	3240	2	27	4725	14x30.5	3780	2	32
14.0	4207	4200	38	3360	2	29	4900	14x31.5	3920	2	33

* Refer to the Ventilator Engineering Manual for Exhaust Volumes and Flow rates not shown above.

Exhaust Flow Rate CFM/ft	Exhaust Static Pressure (in W.C.)
300	0.55
350	0.65
400	0.76
Supply Air Rate	Supply static Pressure ("W.C.)
All Flow Rates	0.20

Notes:

- Exhaust duct can be located anywhere along length of the filter hood.
- For lengths greater than 14' (4270 mm) join multiple sections together.

Spring Air Systems Model No. FD-B with MC Hood Specification

The filter hood shall be a Spring Air Systems model no. FD-B with MC, box canopy, high efficiency, filter hood, with make up air plenum, stainless steel perforated front, down discharge, UL/ULC listed, and built in accordance with the NFPA-96.

The unit casing shall be a minimum 18 GA. Stainless steel with all exposed sides no. 4 finish. The filter hood shall

include UL/ULC listed baffle grease filters mounted in an integral stainless steel rack inclined at 45 degrees. The filter rack shall include a full length stainless steel grease gutter and grease cup. The fire damper shall be an arrangement "D" butterfly type, constructed of 16 Ga. steel with metal blade and edge seals. The fire damper is activated by a fusible link and dead weight arrangement. The make up air plenum shall be insulated with 1" attenuating foam. The hood shall have _____ fluorescent/incandescent light evenly spaced along the length of the hood.

Engineering Data

Item Number _____
 Model Number FD-B with MC _____
 Number of Sections _____
 Hood Length _____
 Hood Width _____
 Lights _____
 Exhaust Volume _____
 No. Of Duct Collars _____
 Size of Duct Collars _____
 Static Pressure _____
 Supply Volume _____
 No. Of Duct Collars _____
 Size Of Duct Collar _____
 Static Pressure _____

FDBWITHMC

