



# DN REV-LOW Maintenance and Operating Manual

---

Spring Air Systems Inc., Oakville, Ontario  
Phone (905) 338-2999, Fax (905) 338-0179, [info@springairsystems.com](mailto:info@springairsystems.com)  
[www.springairsystems.com](http://www.springairsystems.com)

# DN REV-LOW Maintenance and Operating Manual

## Table of Contents

Introduction	1
Spring Air Systems Hood Model Number Designations	2
Principle of Operation	2
VARIFLOW Baffles	3
Baffle Settings	4
<i>REV-LOW</i> Maintenance Instructions	4
Cleaning the Exterior	6
<i>REV-LOW</i> Maintenance Schedule	6
Trouble Shooting	6
Measuring the Exhaust Airflow	7
Installing the Terminator Baffle	8
<i>REV-LOW</i> -Startup Report	9

# DN REV-LOW Maintenance and Operating Manual

## ULC/UL Listed Exhaust Hood without Exhaust Fire Damper

### INTRODUCTION

Thank you for selecting a SPRING AIR SYSTEMS INC. Commercial kitchen exhaust Rev-Low dry extractor. Your system consists of a dry extractor, exhaust fan and on/off switch. Others may have supplied the exhaust fan and on/off operator.

Your SPRING AIR SYSTEMS INC. Dry extractor model was selected to best meet the design requirements of your commercial kitchen application.

The DN series dry ventilator is a UL/ULC listed "Exhaust Hood without Exhaust Fire Damper".

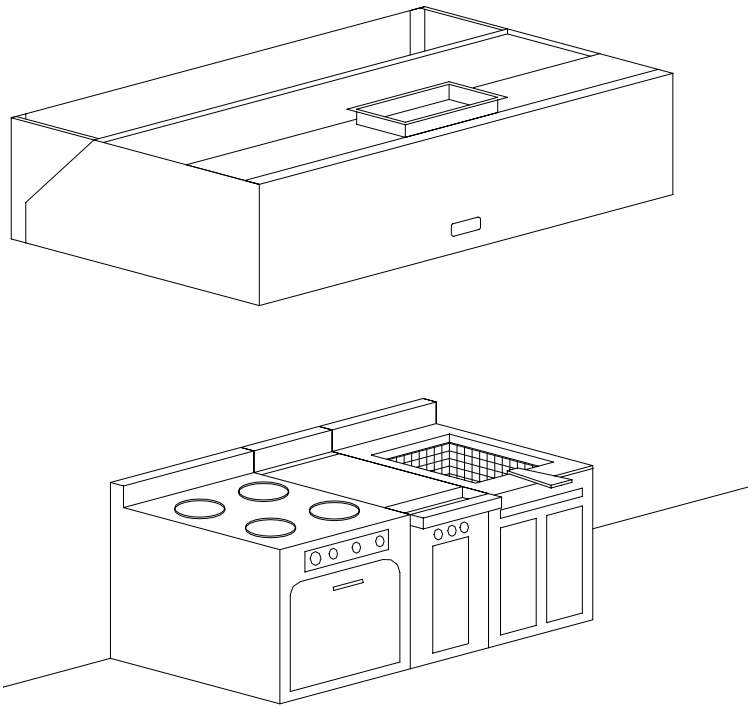

*Typical SPRING AIR SYSTEMS Dry Rev-Low Ventilator Installation  
Figure 1*

An ON/OFF selector switch located in the kitchen area or mounted on the exhaust fan starter coil electrical enclosure normally controls the exhaust fan.

# SPRING AIR SYSTEMS HOOD MODEL NUMBER DESIGNATIONS

There are numerous types and styles of SPRING AIR SYSTEM Rev-Low ventilator available. Refer to the UL/ULC label for the complete model number and exhaust flow requirement for your dry ventilator. The UL/ULC label is located on the underside of the grease through on the right hand side of the dry ventilator.

## SPRING AIR SYSTEMS HOOD MODEL NUMBER DESIGNATIONS

D	Dry Grease Extractor	D	N	B-F	MP	10	4
N	No exhaust fire damper						
D	Fusible link, dead weight fire damper						
B-F	Box type rev-low hood						
MG	Make up air through front grilles						
MP	Make up air through perforated panels						
MC	Make up air down discharge through perforated						
MR	Make up air through rear wall plenum						
10	The length of the ventilator in feet						
4	The width of the ventilator in feet						

Model Number Designation - Ventilators  
Chart No1

## PRINCIPLE OF OPERATION

A commercial kitchen cooking line consists of many different appliances depending on the type of restaurant or institution. In every commercial kitchen the cooking vapors that comprise of grease, smoke, and products of combustion rise off the cooking surface. Natural convection forces drive the cooking vapors up towards the back wall as shown in figure 2. The kitchen dilution air is entrained into the cooking vapors and the air mixture generally follows the profile of the back and top of the hood. The mixture of grease, smoke, products of combustion, lint, dirt and kitchen dilution air proceed along the roof of the hood and follow a path down towards the core extractor slot (the core extractor slot extends along the length of the hood). Most of the air mixture enters the slot and a small amount rolls back into the hood canopy to meet the main air stream again.

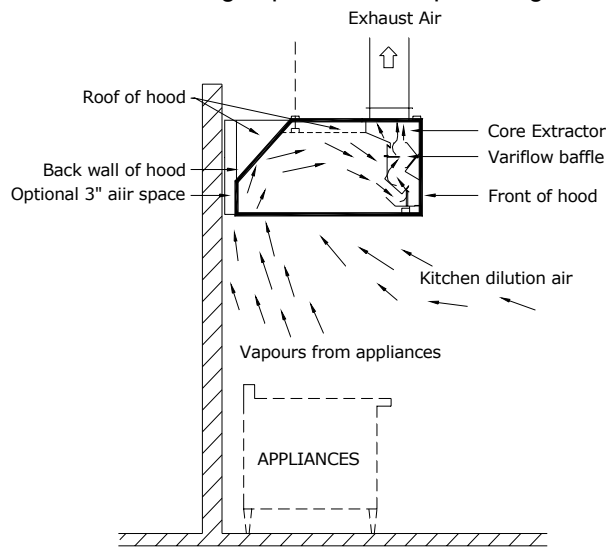

The REV LOW Hood Model DN-B-F  
Figure 2

Optimizing the amount of air mixture that enters the core extractor slot is the key to the REV LOW system. The REV LOW hood must incrementally maximize the amount of the air mixture that enters the slot and minimize the amount of roll back into the canopy as the total amount of the air mixture deviates along the length of the cooking lineup.

# VARIFLOW Baffles

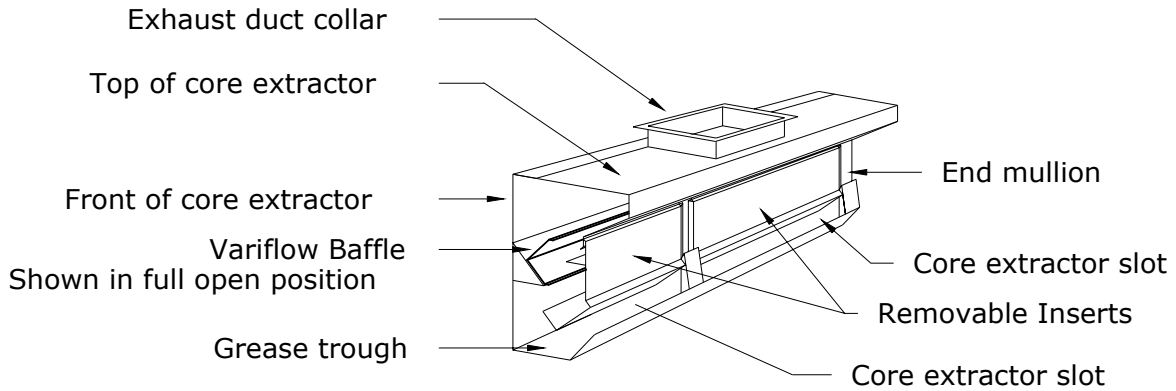

Section View of Core Extractor for DN-B-F REV LOW Hood  
Figure 3

The *REV LOW* accomplishes this complicated process with a unique core extractor profile that contains a series of specially designed *VARI-FLOW* baffles located along length of the core extractor. See Figure 3 above. The *VARI-FLOW* baffles are adjusted prior to shipment to allow the optimum amount of the air mixture to enter the core extractor slot and thereby minimize roll back into the hood canopy. For instance the *VARI-FLOW* baffles located above a Charbroiler are opened to the maximum 450 CFM/ft position and the *VARI-FLOW* baffles located above ovens or steamers are closed to the minimum 90 CFM/ft position. This variable adjustment along the length of each hood provides an exhaust system that truly minimizes the amount of exhaust air to properly ventilate any kitchen line up.

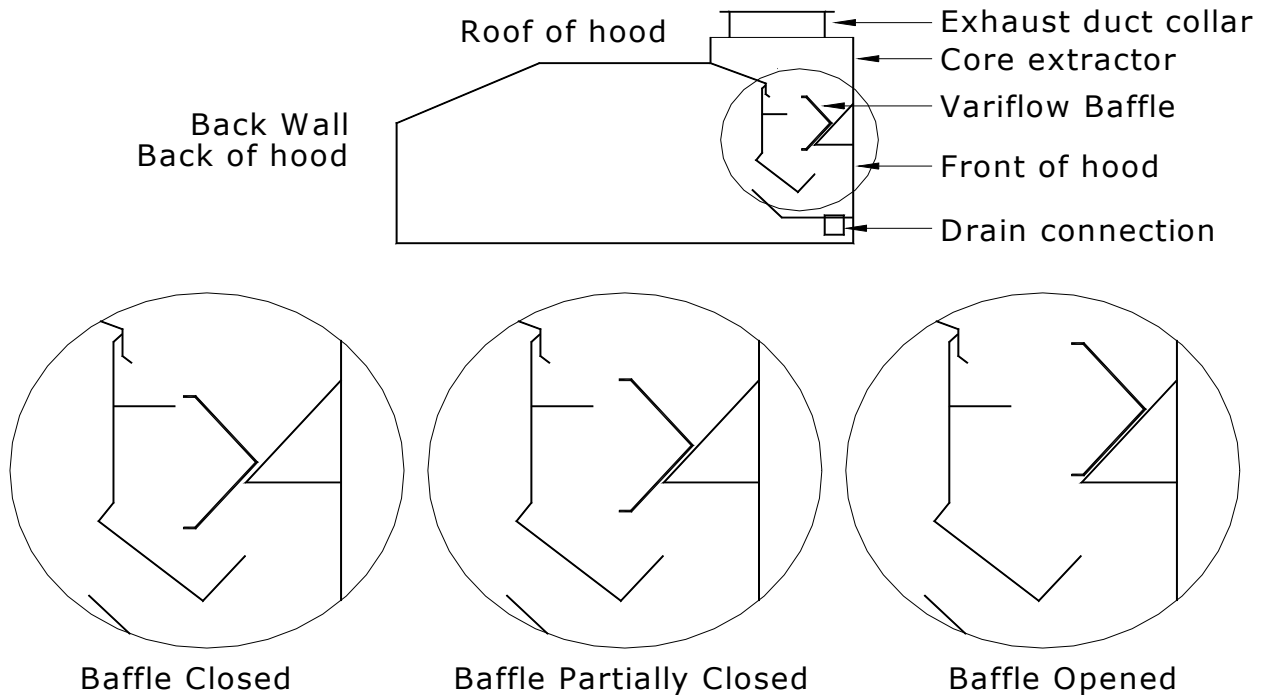

Section View of REV LOW Extractor with Detail of Vari-flow Baffle  
Figure 4

## BAFFLE SETTINGS

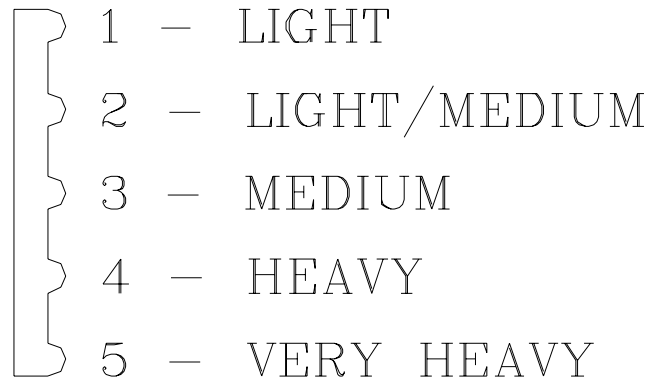

*Vary-flow Baffle labeling  
Figure 5*

Each baffle is factory set base on the type of appliance under the hood.

## REV-LOW MAINTENANCE INSTRUTIONS

*Hood with Spring Air Systems RPD Controller*

### ***At the start of the day***

1. Rotate the occupied/Unoccupied switch to the occupied position to start the exhaust system. The exhaust fan(s) will turn on and after a minute time delay the supply unit(s) will turn on.
2. Check each hood for air movement in the slot. Put your hand up to the entrance of the slot and feel if there is air movement. The air movement should feel the strongest over the heavy appliances. (broilers)



Check Air Flow in slot

Wiping Interior of Hood

3. If there is no air movement check if the green fan light on the Spring Air remote panel is on (If not check the breaker panel or fuse), check if the motor starters have pulled in (Press the red reset button), and finally check fan belts in exhaust fan(s) on the roof. Then call a serviceman.
4. Go to the makeup air diffusers and check for air movement from the supply unit. If no air movement check, motor starter (push red reset button), check fan belts on unit on roof, call a serviceman.
5. Check that all the grease inserts are in the hoods and installed properly.

### ***At the end of the day***

1. After the cooking equipment has been turned off rotate the occupied/Unoccupied switch to the unoccupied position to shut off the exhaust system. The exhaust and supply fan(s) will shut down.
2. The REV-LOW hood will deposit particulate on both the hood backwall and roof. Wipe down the stainless steel backwall above the appliances and the interior of the hood, including the back and roof. Use a recognized hood degreaser. Wipe down the underside of the grease trough. This is located directly above the cooks' head.



Empty Grease Cup

Steam Clean Interior

### ***At the end of every other cooking day***

1. Empty the grease cups located under the grease trough.
2. Remove the grease inserts and wash in a dishwasher or pot sink. . Use a recognized hood degreaser and clean to bare metal.
3. Replace the insert in the hood.

### ***At the end of the cooking day every six months***

1. After removing the grease inserts for cleaning check the position of the Variflow Baffles in the hood. The Variflow Baffles should be open over the heavy equipment and closed over the lighter equipment. (Baffles should be wide open over charbroilers and closed over ovens.
2. Steam clean the interior of the grease extractor



Inspect Baffle Positions

Check Baffle Setting

3. Go to the roof and check the condition of the exhaust fan and makeup air fan belts. Tighten or replace as necessary.
4. Replace the makeup air filters. (Filter replacement times will vary with location of the restaurant)

## CLEANING THE EXTERIOR

Normal soil can be removed with a mild detergent and water mixture applied to a cloth. To remove baked on grease, apply a cleanser to a damp cloth or sponge and rub on the metal in the direction of the polishing lines. DO NOT RUB IN A CIRCULAR MOTION.

Burnt deposits, which do not respond, can usually be removed by rubbing the surface with a SCOTCH-BRITE scouring pad or STAINLESS scouring pads. DO NOT USE ORDINARY STEEL WOOL. Heat tint can be removed by a vigorous scouring in the direction of the polish lines using a SCOTCH BRITE or STAINLESS scouring pad in conjunction with a powdered cleanser.

## REV-LOW MAINTENANCE SCHEDULE

### DAILY:

1. At the end of the cooking day wipe off the interior and exterior of the dry ventilator canopy and the underside of the grease trough with damp clothe.

### WEEKLY:

1. Remove the grease inserts and wash in a mild detergent and water mixture.
2. Cleaning the Hood Exterior

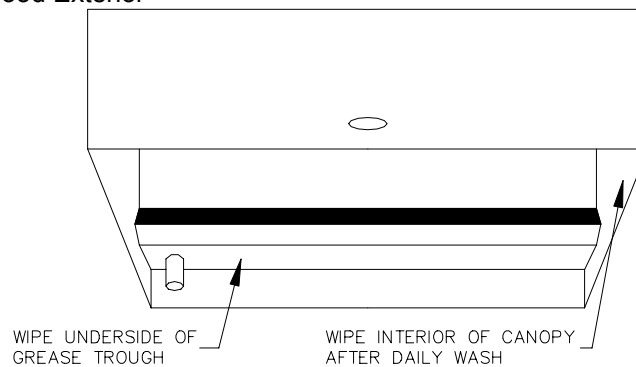

*Cleaning the Hood Exterior  
Figure 7*

Wipe off the interior of the dry ventilator plenum behind the grease extractor inserts and the interior and exterior of the grease trough. Remove the grease cup and clean if necessary.

### SIX MONTHS

1. Check the exhaust fan belts for alignment, tighten, and wear. Adjust an/or replace.
2. Inspect the fusible link fire damper. Clean and/or replace the fusible link if necessary.

## TROUBLE SHOOTING

- |         |       |  |
|---------|-------|--|
| Low air | (i)   | Improper exhaust fan rotation.                 |
|         | (ii)  | Broken or slipping belt.                       |
|         | (iii) | Exhaust ductwork inspection door open.         |
|         | (iv)  | Obstruction in the ductwork.                   |
|         | (iv)  | Flow-flow baffle must be adjusted              |
| No Air  | (i)   | Broken belt.                                   |
|         | (ii)  | Exhaust fan overload tripped.                  |
|         | (iii) | Exhaust fan disconnect open.                   |
|         | (iv)  | Exhaust fan motor fuse blown.                  |
|         | (v)   | Fire damper closed.                            |
|         | (v)   | Check if baffles are upside down in extractor. |

## REMOVEABLE INSERT INSTALLATION

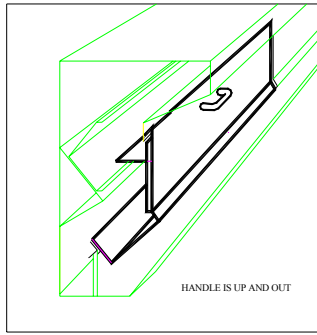

CORRECT

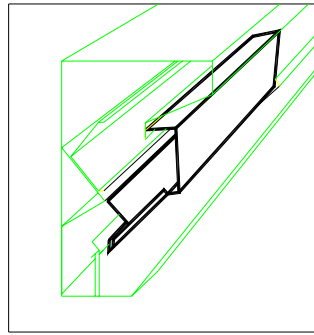

UP SIDE DOWN

## MEASURING THE EXHAUST AIRFLOW

The exhaust air is measured along the inlet slot of the ventilator. To ensure accurate results take a reading every foot along the length of the ventilator is recommended.

### VANAXIAL VELOMETER

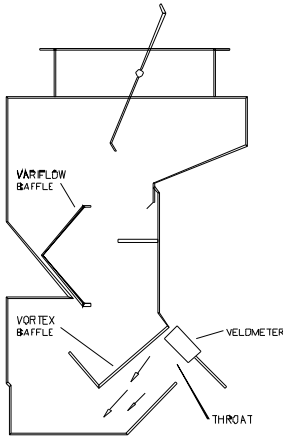

Hold the instrument perpendicular to the VORTEX BAFFLE and parallel to the throat (inlet slot) of the ventilator. Velometer should not exceed three inches in diameter.

Measuring Exhaust Air  
Figure 8

### PITOT TUBE OR ANEMOMETER

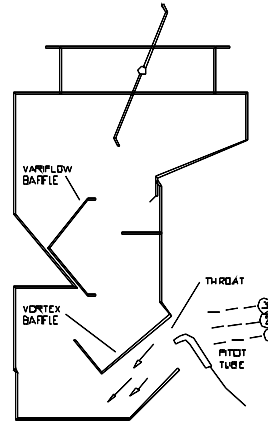

Hold the instrument perpendicular to the VORTEX BAFFLE and parallel to the throat (inlet slot) of the ventilator. Take three readings across the throat and average the results.

Measuring Exhaust Air  
Figure 9

## Calculating the Exhaust Air

Calculate the average velocity across the inlet slot and refer to the chart below for the corresponding CFM/ft (l/s/m).

Ventilator Type	Velocity		Exhaust Air Volume	
	Fpm	m/s	CFM/ft	l/s/m
DN-B-F/DN-DI	450	2.3	100	140
DN-B-F/DN-DI	675	3.4	150	210
DN-B-F/DN-DI	900	4.6	200	275
DN-B-F/DN-DI	1125	5.7	250	340
DN-B-F/DN-DI	1350	6.9	300	410
DN-B-F/DN-DI	1575	8.0	350	480
DN-B-F/DN-DI	1800	9.2	400	550
DN-B-F/DN-DI	2000	10.2	450	620
DN-B-F/DN-DI	2250	11.5	500	690
DN-B-F/DN-DI	2450	12.5	550	755

Chart 1

## INSTALLING THE TERMINATOR BAFFLE

The TBDD Terminator baffle is available in various lengths to suit adverse site

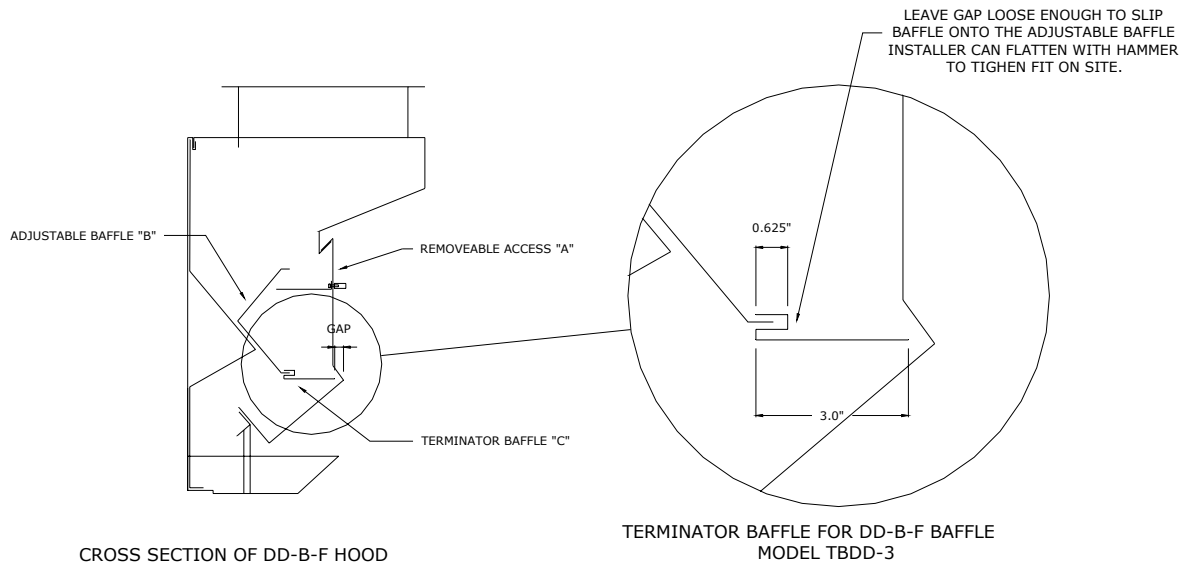

conditions. This will provide additional exhaust air over heavy appliances that are being effected by the surrounding environment.

### Installation:

Remove the TBDD from the packing material. Take off all of the Removable Access Doors "A" from the hood. You should be able to clearly see all the adjustable baffles "B" and their settings. Ensure that the adjustable baffle(s) "B" over the heavy appliance is set at 5. The TBDD baffles "C" are going to be installed on the adjustable baffles "B" over the light appliances. To install the TBDD baffle "C" onto the adjustable baffle "B" simply line up the gap on the TBDD baffle "C" with the lower end of baffle "B". Tap the TBDD along the length until it is snug on baffle "B". If the fit is loose remove the TBDD baffle "C" and gently tap the gap with a hammer in the middle and at each end. Re-attach to baffle "B".

Install these baffles on the two adjustable baffles "B" located on the right or left side of the charbroiler (when looking from the front of the hood).

### VARIFLOW BAFFLE "B" ARRANGEMENT

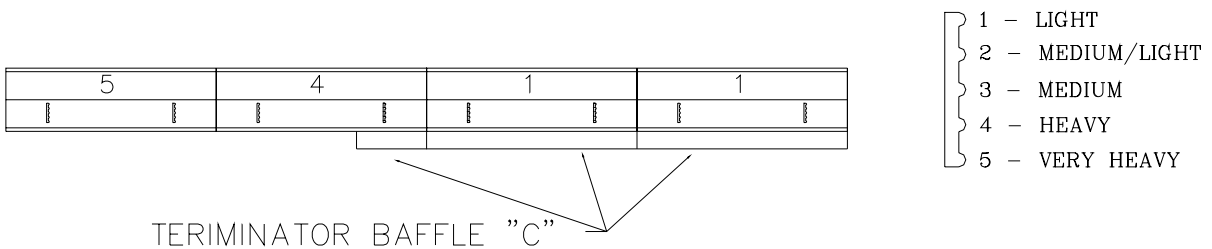



# REV-LOW- STARTUP REPORT

## General Information

Job Name				
Date				
Customer				
Location				
Spring Air Service				
Exhaust Fan Model No.				
Manufacturer				
Up blast Discharge	yes		no	
Exhaust Fan HP				
Exhaust Air Design (CFM)				
Supply Air Design (CFM)				
Ventilator mounting Height from finished floor to front of hood				
Make Up Air Systems	Good	Fair	Poor	None

<b>Hood Item</b>			
Model		Length	
Width		No. of Baffles	
Baffle Size *		Design CFM	
<b>Baffle No. Left to Right</b>	<b>Baffle Setting</b>	<b>Velocity Reading (fpm)</b>	<b>Calculated Exhaust Volume per Baffle (CFM) **</b>
1			
2			
3			
4			
5			
6			
<b>Total Exhaust Measured CFM</b>			
<b>Design Exhaust CFM</b>			

<b>Hood Item</b>			
Model		Length	
Width		No. of Baffles	
Baffle Size *		Design CFM	
<b>Baffle No. Left to Right</b>	<b>Baffle Setting</b>	<b>Velocity Reading (fpm)</b>	<b>Calculated Exhaust Volume per Baffle (CFM) **</b>
1			
2			
3			
4			
5			
6			
<b>Total Exhaust Measured CFM</b>			
<b>Design Exhaust CFM</b>			

<b>Hood Item</b>			
Model		Length	
Width		No. of Baffles	
Baffle Size *		Design CFM	
<b>Baffle No. Left to Right</b>	<b>Baffle Setting</b>	<b>Velocity Reading (fpm)</b>	<b>Calculated Exhaust Volume per Baffle (CFM) **</b>
1			
2			
3			
4			
5			
6			
<b>Total Exhaust Measured CFM</b>			
<b>Design Exhaust CFM</b>			

<b>Hood Item</b>			
Model		Length	
Width		No. of Baffles	
Baffle Size *		Design CFM	
<b>Baffle No. Left to Right</b>	<b>Baffle Setting</b>	<b>Velocity Reading (fpm)</b>	<b>Calculated Exhaust Volume per Baffle (CFM) **</b>
1			
2			
3			
4			
5			
6			
<b>Total Exhaust Measured CFM</b>			
<b>Design Exhaust CFM</b>			

<b>Hood Item</b>			
Model		Length	
Width		No. of Baffles	
Baffle Size *		Design CFM	
<b>Baffle No. Left to Right</b>	<b>Baffle Setting</b>	<b>Velocity Reading (fpm)</b>	<b>Calculated Exhaust Volume per Baffle (CFM) **</b>
1			
2			
3			
4			
5			
6			
<b>Total Exhaust Measured CFM</b>			
<b>Design Exhaust CFM</b>			

*Other Fine Products From*

## ***SPRING AIR SYSTEMS...***

- Water Wash Ventilators
  - ◆ Hot Water Wash
  - ◆ Cold Water Spray/Hot Water Wash
  - ◆ Water Wash Control Panels
- Dry Extractor Hoods
- ***REV-LOW*** Hoods
- Cartridge Hoods
- Filter Hoods
- Surface Fire Suppression
- Commercial Kitchen Exhaust Fans
- Kitchen Enviro Systems
  - ◆ KES - 100% Exhaust
- Commercial Kitchen Supply Units
- Compensating Hoods
- Exhaust Fans
- Supply Fans
- Commercial Kitchen Control Panels
- Variable Speed Exhaust/Supply Systems

Phone: 905-338-2999, FAX: 905-338-1079, e-mail [info@springairsystems.com](mailto:info@springairsystems.com)  
[www.springairsystems.com](http://www.springairsystems.com)